

1. Technical parameters

- 1.1 Nominal pressure - 25MPa.
- 1.2 Nominal flow - 120 dm³/min

Drawn By	Stoev	28.08.2008	sheet	1/5	material	
CheckBy	Todorov		scale	1:2		
					description	weight kg
					Monoblock PX120	32.920
					N _e	
					12620.00.00.00	

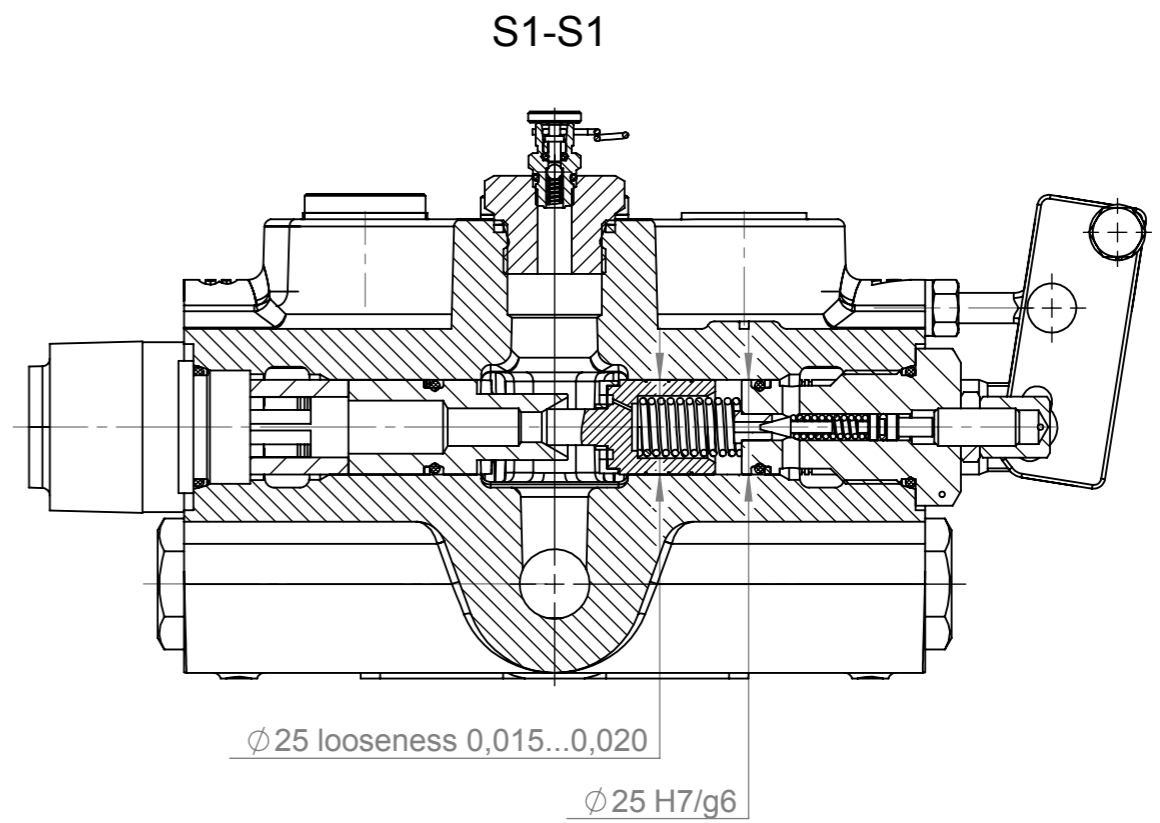
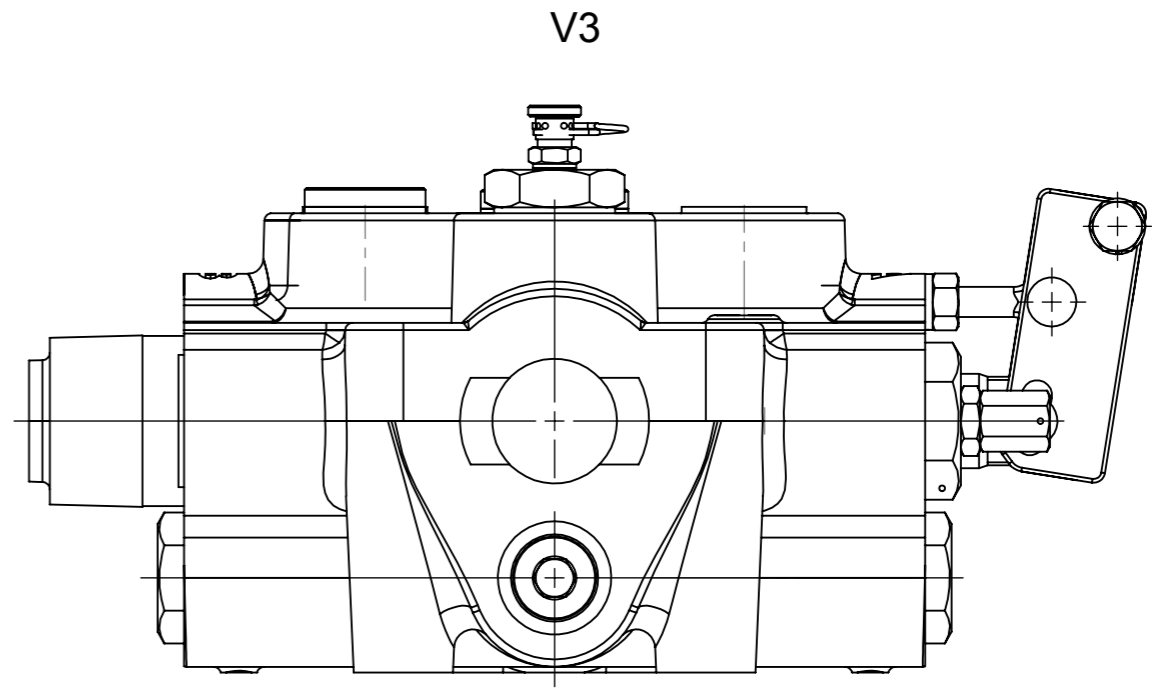
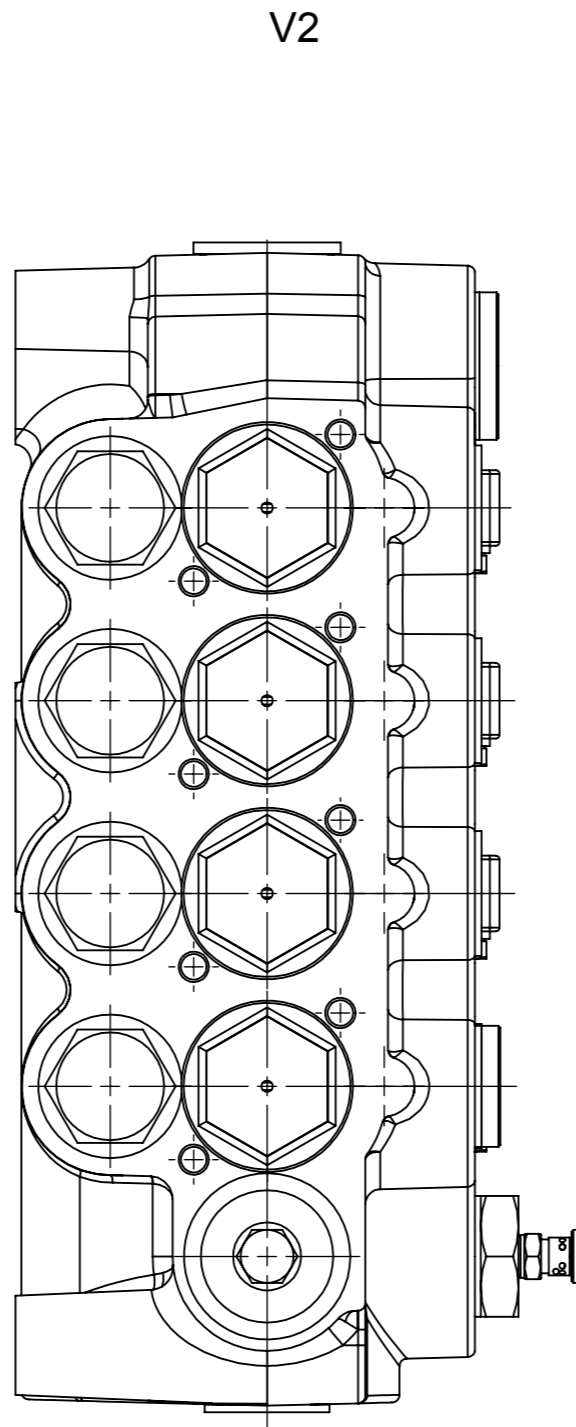
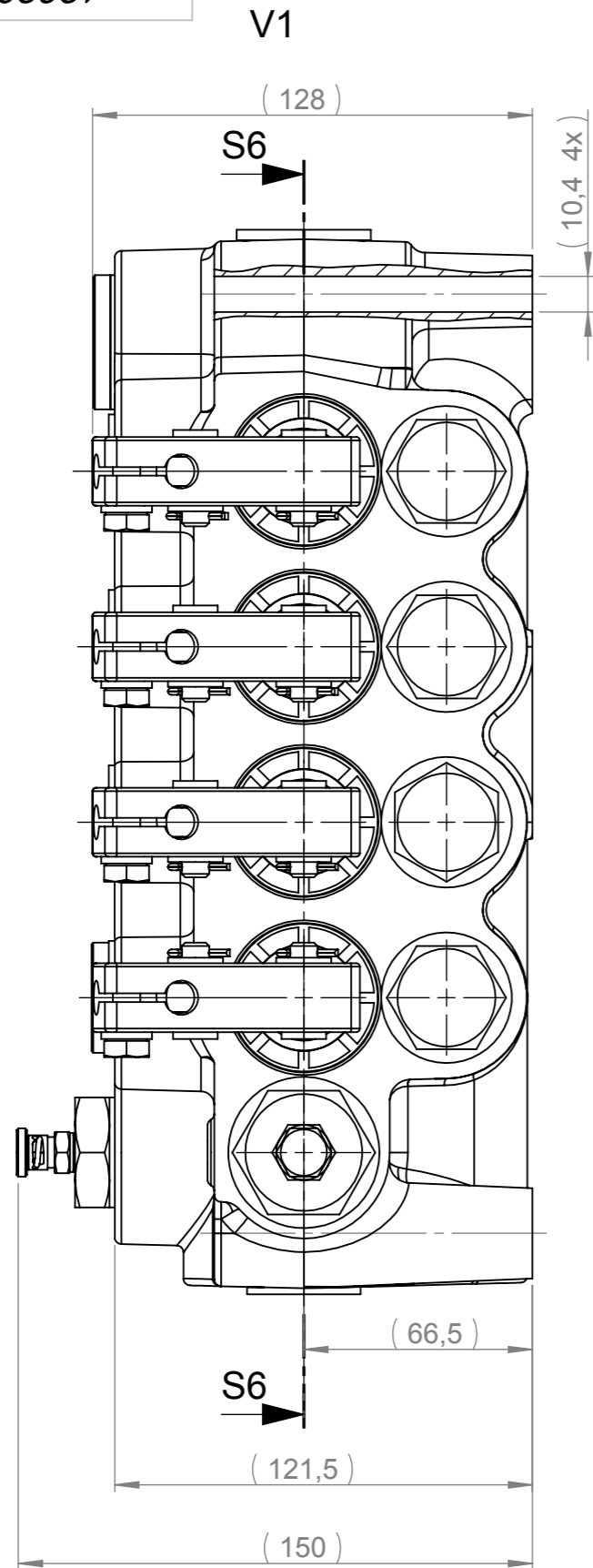

Note
 1. Hydraulic valves with reduced looseness between spool and housing are executed with looseness 0.006...0.008 and are marked "n" after the distribution scheme of the relevant spool
 2. If the way of centering and fixing is one and the same for all spools, the type of centering is noted only on the first spool

Drawn By	Stoev	28.08.2008	sheet	2/5	material	
CheckBy	Todorov		scale	1:2		
					description	Monoblock PX120
					weight kg	32.920
					Nº	12620.00.00.00

